

15. Picton, S., Barton, S. L., Bouzayen, M., Hamilton, A. J. and Grierson, D., Altered fruit ripening and leaf senescence in tomatoes expressing an antisense ethylene-forming enzyme transgene. *Plant J.*, 1993, **3**, 469–481.
16. Bird, C. R. *et al.*, The tomato polygalacturonase gene and ripening-specific expression in transgenic plants. *Plant Mol. Biol.*, 1988, **11**, 651–662.
17. Dellapenna, D., Lincoln, J. E., Fischer, R. L. and Bennett, A. B., Transcriptional analysis of polygalacturonase and other ripening associated genes in *Rutgers*, *rin*, *nor* and *Nr* tomato fruit. *Plant Physiol.*, 1989, **90**, 1372–1377.
18. Montgomery, J., Pollard, V., Deikman, J. and Fischer, R. L., Positive and negative regulatory regions control the spatial distribution of polygalacturonase transcription in tomato fruit pericarp. *Plant Cell*, 1993, **5**, 1049–1062.
19. Jakubowicz, M., Jolkowska, J., Kwapiszewska, G., Krecisz, A. and Czerski, P., RFLP analysis of 1-aminocyclopropane-1-carboxylate synthase *ACC2* and *ACC4* genes from polish cultivars of tomato. *Acta Biochim. Pol.*, 2002, **49**, 1037–1042.

ACKNOWLEDGEMENTS. We thank Drs M. L. Lodha and Anil Saxena for help with ethylene measurements. K. N. A. acknowledges financial assistance received in the form of Senior Research Fellowship by the Council of Scientific and Industrial Research, New Delhi. The work reported is part of the Ph D thesis by K.N.A.

Received 13 October 2003; revised accepted 23 June 2005

## Anomalous fluctuation of radon, gamma dose and helium emanating from a thermal spring prior to an earthquake

Nisith K. Das<sup>1</sup>, Rakesh K. Bhandari<sup>1</sup>,  
Debasis Ghose<sup>2</sup>, Prasanta Sen<sup>2</sup> and  
Bikash Sinha<sup>1,2,\*</sup>

<sup>1</sup>Variable Energy Cyclotron Centre, and

<sup>2</sup>Saha Institute of Nuclear Physics, 1/AF, Bidhan Nagar, Kolkata 700 064, India

**Anomalous large-scale radon emission, striking high gamma dose rate and significant increase in He/CH<sub>4</sub> ratio have been observed in thermal spring emanations at Bakreswar, West Bengal prior to the recent major earthquake near the island of Sumatra, Indonesia. An attempt has been made to correlate the field observations as the precursory phenomena to the quake.**

**Keywords.** Earthquake, gamma, helium, radon, thermal springs.

RESEARCH dealing with earthquake prediction has drawn serious attention of geophysicists as well as investigators in different branches of natural sciences in many countries across the globe for over several decades. It is a problem

that is as yet unresolved, only because of its sheer complexity. Although no reliable method to accurately foretell the time, place and magnitude of an impending earthquake has as yet been established, it has been reported that several earthquakes are heralded by the occurrence of foreshocks that can be detected by various dense local monitoring networks. A seismic event might start with a pre-slip stage, hours to days before the earthquake<sup>1</sup>. This pre-slip nucleation phase would be silent and too slow to be picked up with conventional seismic instrumentation. There are other instruments that can measure seismic-induced deviations, such as changes in the level of radon and helium gas<sup>2–17</sup>, electrical<sup>18</sup> and magnet properties<sup>19</sup>, velocity changes of seismic waves, high-energy charged particle flux variations in space<sup>20</sup> and even abnormal animal behaviour<sup>21–24</sup>. We do not have direct access to observing deep earth phenomena, especially those relating to the curious behaviour of heterogeneous rock structures during the build-up of an earthquake. However, crustal changes that occur during the process find expression in changes in gas geochemical features in spring emissions and hydrothermal activity. Changes in the concentration of subsurface volatile components discharged from spring vents across time may be exploited to extract useful information related with deep earth phenomena that result in changes in the contour and content of gas emission at surface level.

Studies relating geochemical changes to seismic occurrences based on phenomenological approach and short-term precursory observations are available<sup>3–6,12</sup>. Some of these are found to coincide with the subsequent occurrence of tectonic activities.

A strong earthquake or large-scale disturbance of the ocean floor, such as landslides or volcanic eruptions can generate a potentially dangerous tsunami<sup>25</sup>. Its threat lies in the great speed at which it travels (as much as 950 km/h), its long wavelength (up to 200 km), its low observable height in the open ocean and its ability to pile up rapidly to heights of 30 m or more as it moves into shallow water along an exposed coast. The suddenness of the arrival of a tsunami and consequent lack of warning time results in numerous casualties and catastrophic devastation, when the tsunami moves into populated areas, as we have recently seen in South East Asian countries.

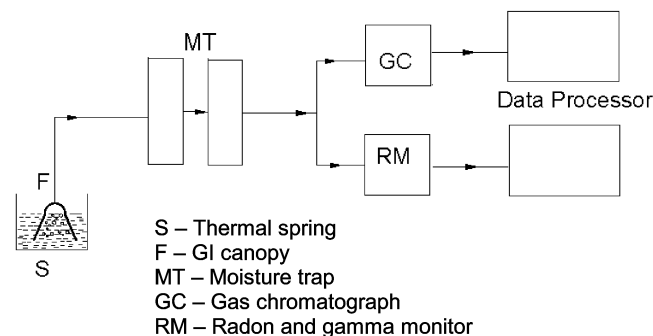

**Figure 1.** Block diagram of integrated experimental arrangement.

\*For correspondence. (e-mail: bikash@tnp.saha.ernet.in)

A distinctive feature of the earth is to emit gaseous volatiles from deep inside to the surrounding atmosphere. The release of sub-surface gas principally takes place from fractured and faulted tracts, and the other natural openings such as geothermal and hydrothermal outlets. In an attempt to improve the basic understanding of the process of deep-earth gas emissions and their relation to seismic occurrences, a research project has been undertaken at Bakreswar (23°52'30"N; 87°02'30"E), Birbhum District, West Bengal, India. This spring is known to be tectonically sensitive. The project seeks to establish a continuous and real-time monitoring of the spring gas parameters over a long

period. It is expected to obtain a sufficient large databank commensurate with long-time statistics. A direct transfer of the gas sample to installed analytical instruments ensures eliminating uncertainties in sampling and errors due to leakages that are likely to occur in off-line analysis performed after a lapse of time.

Here we report the recent observations of anomalous large-scale radon emission, striking high gamma dose rate and significant increase in He/CH<sub>4</sub> ratio in the thermal spring emanations at Bakreswar prior to the devastating earthquake of about 8.9 on the Richter scale near the island of Sumatra, Indonesia on 26 December 2004.

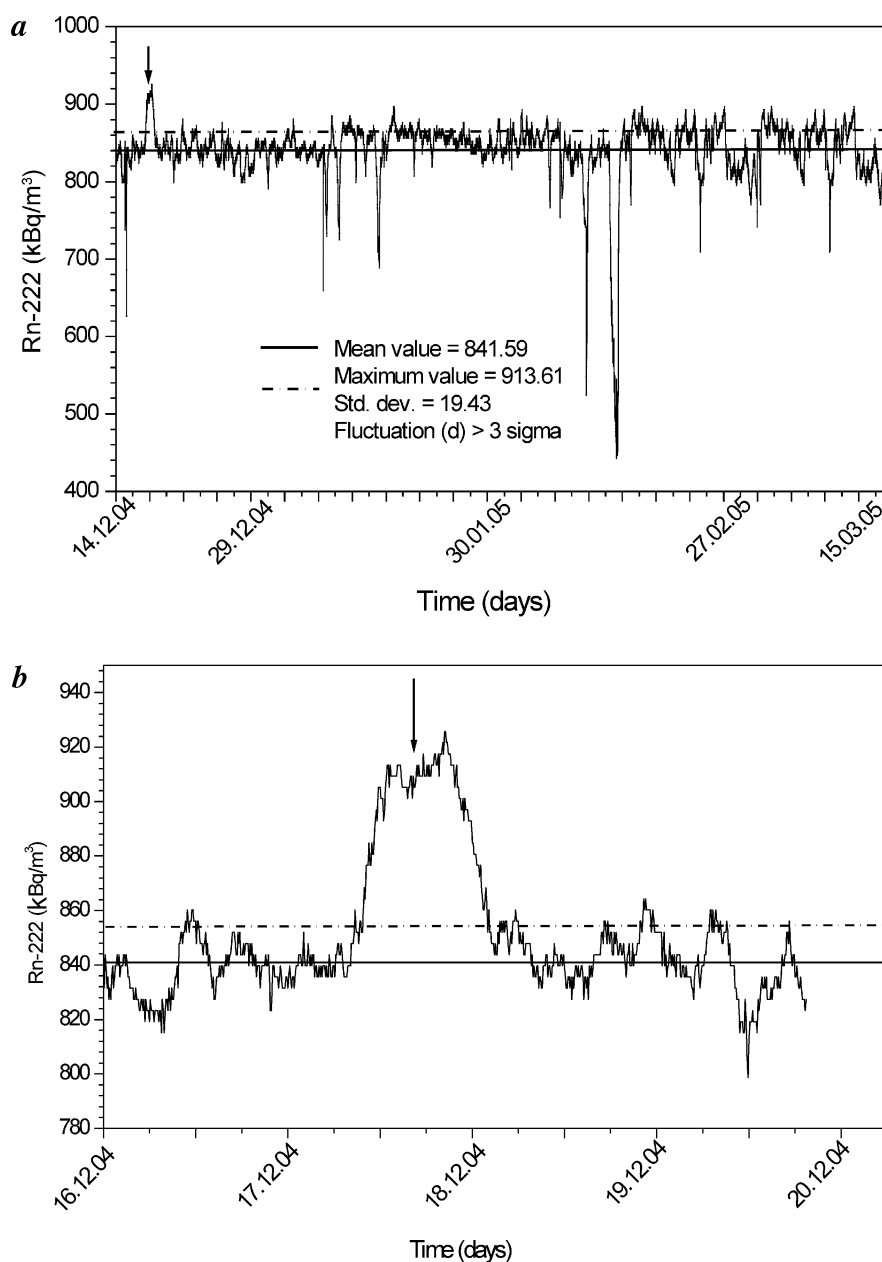

**Figure 2.** *a*, Temporal variation of radon-222 in thermal spring gases over an extended period. *b*, Variation of radon-222 during 16 to 20 December 2004.

The experimental set-up at Bakreswar consisted of a computer-assisted gas measurement system, helium in particular, a radon and gamma dose monitoring instrument and a radon progeny-measuring device. All the equipments are directly integrated with the spring vent, as shown in Figure 1. Escaping bubbles from the spring vents are trapped underwater beneath an inverted SS funnel (F), and flow through 6.2 mm OD SS tubing through a series of moisture traps (MT), containing anhydrous  $\text{CaCl}_2$  for drying the gas. Gas concentration changes are monitored by a gas chromatograph (GC, Chemito, Model-8610 HT), consisting of a micro thermal conductivity detector (*m*-TCD), capillary

column and auto-sampling valve as injector. Sampling interval and data acquisition of the chromatograph are done through a C2000 Windows-based data station. Ultra pure hydrogen gas is used as the carrier gas. A radon monitor (RM) type PQ2000 PRO Alpha Guard provided with Data-Expert professional software registers changes in spring gas radon concentrations. The instrument has a resolution of  $1 \text{ Bq/m}^3$  and can determine Rn-222 concentrations from 2 to  $2 \times 10^6 \text{ Bq/m}^3$ . It is also equipped with a GM tube to measure gamma dose rate. The gamma measuring range is from 20 nSv/h to 10 mSv/h with a resolution of 1 nSv/h.

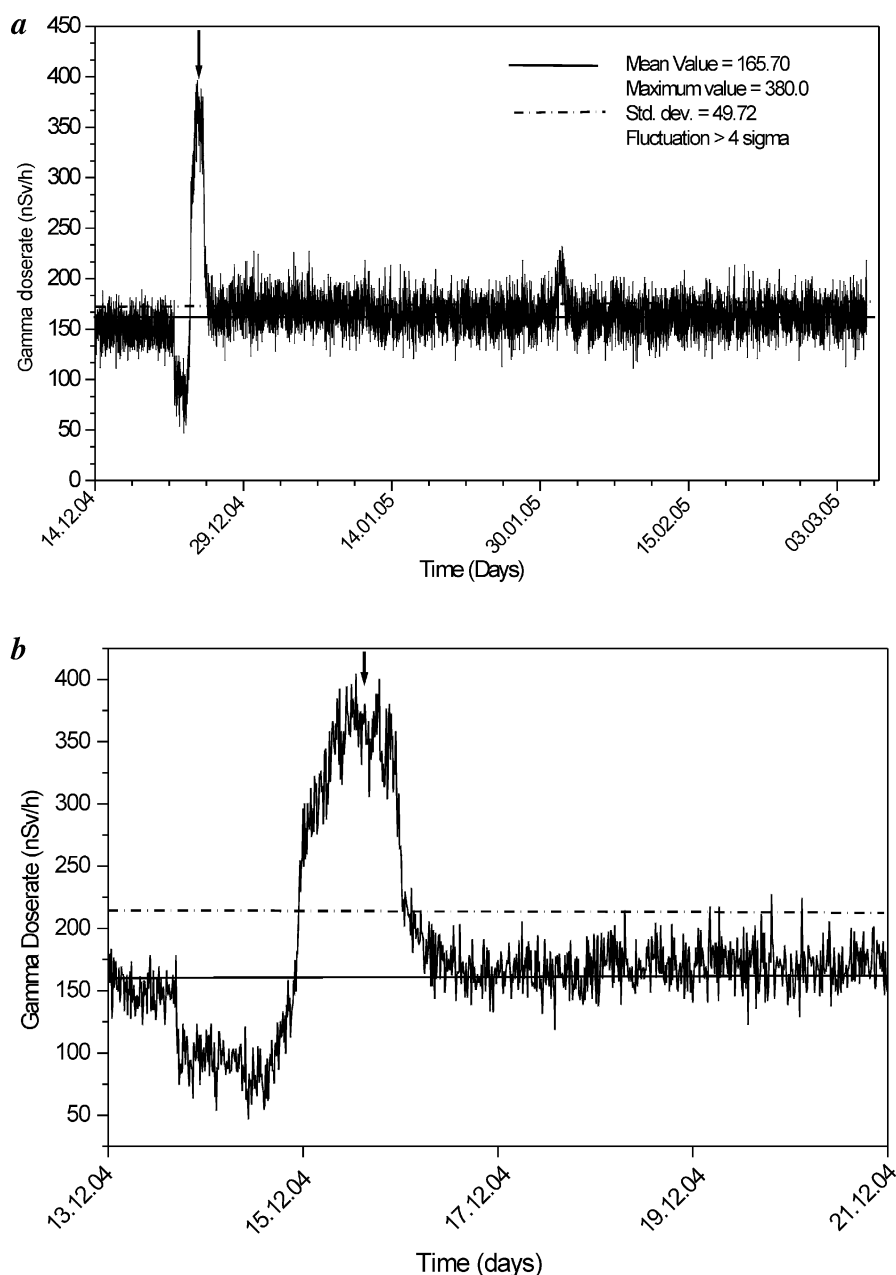
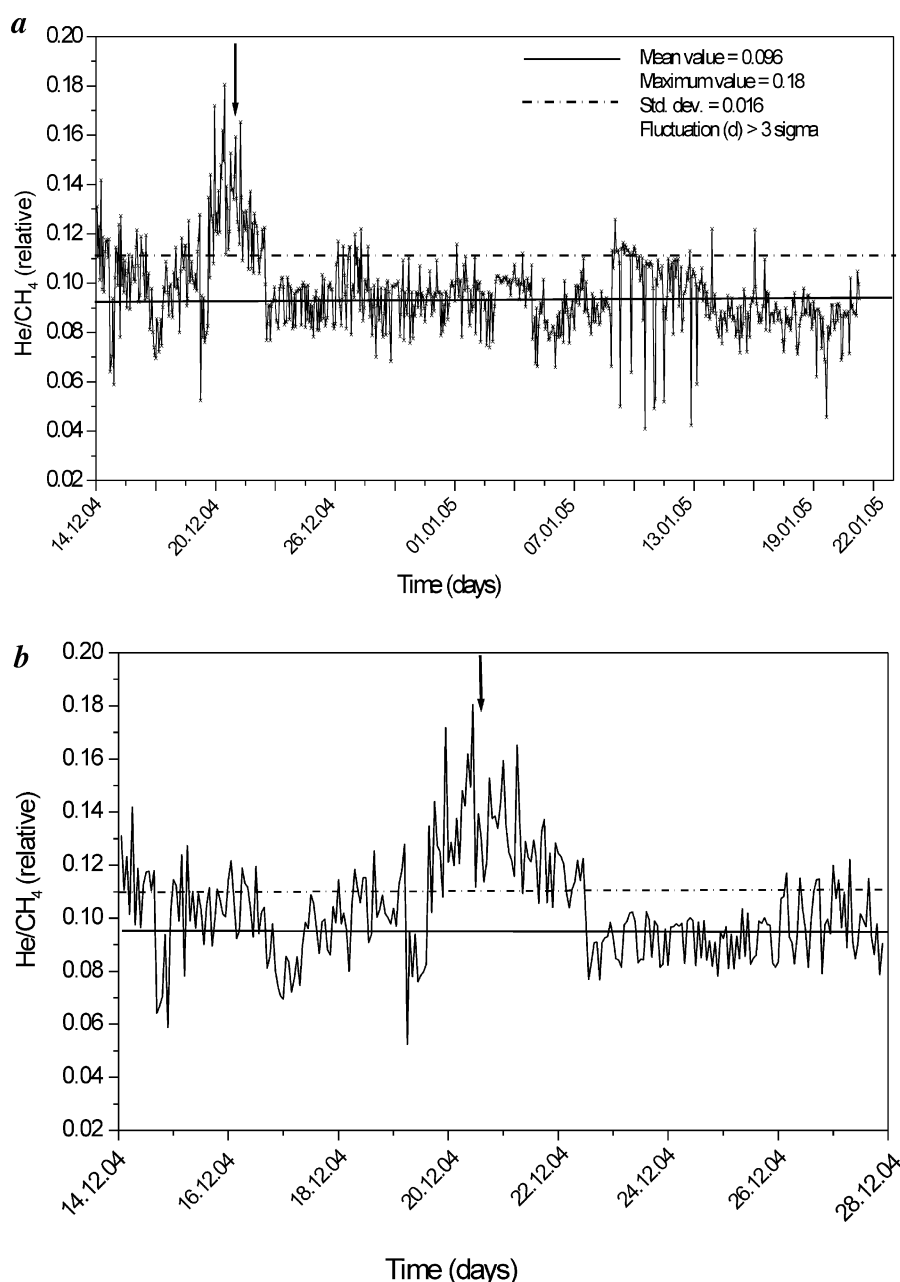

**Figure 3.** *a*, Temporal variation of gamma dose in thermal spring gases over an extended period. *b*, Variation of gamma dose during 13 to 21 December 2004.

Continuous and simultaneous data collection has been in progress for some time with a sampling interval of 1 h for helium, and 10 min for radon and gamma dose. An UPS that can override prolonged normal power failure assures uninterrupted power supply. Adequate precautionary measures have been taken to ensure that the observed anomalous changes in the data are not caused by meteorological factors, but can indeed be caused by changes in tectonic stress field or structure. The test site is composed of a cluster of small openings with gas flow rate of 3.5 slpm at a temperature of 67–70°C. Radon is carried by the escaping thermal spring gas primarily consisting of nitrogen

(92.2 vol%), besides methane, oxygen, argon and helium. The gases are released from the spring vents at an absolute pressure of about 1.6 bar. Thus atmospheric pressure changes have little effect, if any, on variations in spring gas concentrations or in the gas flow rate. Geochemical parameters that are most affected by tectonic changes are helium, radon and gamma dose. Therefore, they appear to be promising factors in a monitoring programme seeking linkage with seismic events of varying magnitudes.

We present here observations made during the monitoring period beginning from mid-December 2004 to mid-March 2005. The recent major earthquake that occurred in Indonesia



**Figure 4.** *a*, Temporal variation of He/CH<sub>4</sub> ratio in thermal spring gases over an extended period. *b*, Variation of He/CH<sub>4</sub> ratio during 14 to 28 December 2004.

(26 December 2004) was during this timespan. Large anomalies in radon concentration, striking high gamma dose and unusual increase in the He/CH<sub>4</sub> ratio were observed during this period. We find the ratio He/CH<sub>4</sub> to be a better index of seismic variations than either He or CH<sub>4</sub> taken separately. The time series data derived from *in situ* measurements of radon, gamma dose and He/CH<sub>4</sub> taken at the spring site are plotted in Figures 2–4, respectively. It is seen that during seismically quiescent periods, variations of all the three monitored parameters are of pulsed nature with average concentrations of  $841.59 \pm 19.43$  kBq/m<sup>3</sup> for radon,  $165.70 \pm 49.72$  nSv/h for gamma dose rate and 0.096 ± 0.016 for He/CH<sub>4</sub> ratio.

On 17 and 18 December 2004, amplitude of variation of radon concentration sharply increased to around 913.61 kBq/m<sup>3</sup> as shown in Figure 2b, which is greater than 3s. Some sharp negative <sup>222</sup>Rn anomalies have been recorded during the period January to March 2005, as shown in Figure 2a. Earlier similar negative peaks have been observed by some workers<sup>6,10,14,26</sup>. Most of the negative fluctuations, except one, are of short persistence. The observed such short-duration peaks may be ascribed to transient blockage in the gas-flow channels, thereby reducing the radon permeability due to fluid–rock interaction or a transient inflow of circulating water. The somewhat longer duration of negative peak for radon concentration during 16–18 February 2005 resembles the signature of a pre-seismic disturbance.

The gamma dose rate increased steeply to 380.0 nSv/h as shown in Figure 3b, and this fluctuation is more than 4s on 14 and 15 December 2004. The observed gamma signal is the composite gamma emission due to the decay of radon and its short-lived daughters <sup>218</sup>Po, <sup>214</sup>Po, <sup>214</sup>Bi and <sup>214</sup>Pb. While gamma is associated in all the transitions, the observed gamma is principally due to <sup>214</sup>Pb ( $t_{1/2} \sim 26.8$  m). The sudden spurt of the gamma dose, most likely, has a bearing on the deep earth activity, particularly, in the mechanically weak tracts of the solid earth. The dip in the dose rate prior to significant peaking is consistent and promising.

The remarkable increase in He/CH<sub>4</sub> ratio to a value of 0.18 between 20 and 22 December 2004, was recorded and the amplitude swing in He/CH<sub>4</sub> was more than 3s. The earthquake initiation mechanism brings about the change in thermodynamical state of the fluid reservoir and affects the distribution of the stress field. This, in turn, leads to enhanced permeation of deep earth volatiles and helium in particular.

The seismo-tectonic responses of the three observed parameters are alike in nature, but are not simultaneous. The standard deviation has been calculated considering all data-points, excluding data for observables during the period of sharp increase. Since statistical fluctuations above 2s are considered to be anomalous and the recorded spring parameters are well above 3s, the large anomalies noted in the gas geochemical parameters may well be attributed to the catas-

trophic cause<sup>14,27</sup>. Our findings of large-scale anomalous fluctuations in spring gas composition at Bakreswar a few days prior to the major earthquake on 26 December 2004, are quite compatible with similar observations reported earlier by other investigators studying earthquake precursory phenomena worldwide.

The anomalous fluctuation of radon, gamma dose and helium emanating from the thermal spring may have resulted from (i) relative increase in heat flow, (ii) stress-induced pore collapse and (iii) stress-induced micro fracturing. The observed effect could be attributed to any one of the three or a possible combination thereof. There have been several attempts in the past to correlate the event, earthquake, with laboratory observable as a precursory phenomenon. The weighted average of all the literature-based data favours a partial success towards such an attempt.

The occurrence of foreshocks is mostly random and they precede the main shocks with an intensity which is a function of depth, epicentral distance, distribution of the stress field across the earthquake preparation zone and the main shock-slip orientation<sup>28</sup>. The observed fluctuation may well tentatively be explained as follows. High frequency seismic waves originating from the foreshocks carry substantial amount of energy through the earth and are responsible for instantaneous stress changes and diffusive processes at depths of the earth's interior. Dilatation and compression effects of these waves are likely to cause perturbation in the thermodynamic state of the geothermal reservoirs located at different distances, resulting in disruption of the physico-chemical balance and fluid composition. Consequently, the changed pore pressures coupled with micro fracturing, increases the permeability of the host rocks, enthalpy of the reservoir increases leading to enhancement of gas concentration.

1. Ellsworth, W. L. and Beroza, G. C., *Science*, 1995, **268**, 851–854.
2. Planinic, J., Radolic, V. and Vukovic, B., *Nucl. Instrum. Methods Phys. Res. A*, 2004, **530**, 568–574.
3. Roeloffs, E. A., *PAGEOPH*, 1988, **126**, 177–209.
4. Wilson, D. C., <http://www.ees.nmt.edu/~davew/rweb/eqpaper2.htm>, 2005, pp. 1–8.
5. Gold, T., <http://www.people.cornell.edu/pages/tg21/Earthq.html>, 1994, pp. 1–9.
6. Toutain, J. P. and Baubron, J. C., *Tectonophysics*, 1999, **304**, 1–27.
7. Barsukov, V. L., Varshal, G. M. and Zamokina, N. S., *PAGEOPH*, 1984/85, **122**, 143–156.
8. Ghose, D., Das, N. K. and Sinha, B., *Curr. Sci.*, 1996, **71**, 56–58.
9. Chalov, P. I., Tuzova, T. V. and Alekhiva, V. M., *Dokl. Akad. Nauk SSSR*, 1976, **231**, 1331–1334.
10. Wakita, H., Igarashi, G. and Notsu, K., *Geophys. Res. Lett.*, 1991, **18**, 629–632.
11. Igarashi, G. *et al.*, *Science*, 1995, **269**, 60–61.
12. Wakita, H., *Proc. Natl. Acad. Sci. USA*, 1996, **93**, 3781–3786.
13. Ghose, D., Das, N. K., Sinha, B., Das, S. K. and Chatterjee, S. D., *Proc. Indian Natl. Sci. Acad.*, 1994, **60**, 481–486.
14. Heinicke, J. and Koch, U., *Pure Appl. Geophys.*, 2000, **157**, 1621–1641.
15. Virk, H. S., Walia, V. and Kumar, N., *J. Geodyn.*, 2001, **31**, 201–210.

16. Majumdar, K., *Curr. Sci.*, 2004, **86**, 1288–1292.
17. Beroza, G. C. and Ellsworth, W. L., *Tectonophysics*, 1996, **261**, 209–227.
18. Madden, T. and Mackie, R., *Proc. Natl. Acad. Sci. USA*, 1996, **93**, 3776–3780.
19. Fraser-Smith, A. C., Bernardi, A., McGill, P. R., Ladd, M. E., Hellwell, R. A. and Villard, O. G., *Geophys. Res. Lett.*, 1990, **17**, 1465–1468.
20. Galper, A. M., Koldashov, S. V., Murashov, A. M., Ozerov, Y. V. and Voronov, S. A., [www.pereplet.ru/pops/quakes/quakes.html](http://www.pereplet.ru/pops/quakes/quakes.html), 1995, pp. 1–5.
21. Rikitake, T., Oshiman, N. and Hayashi, M., In *Developments of Solid Earth Geophys.*, Elsevier, 1976, no. 9.
22. Hatai, S. and Abe, N., *Proc. Imp. Acad. Jpn.*, 1932, **8**, 375–378.
23. Suyehiro, Y., *Bull. Earthquake Res. Inst. Univ. Tokyo, Suppl.*, 1934, **1**, 228–231.
24. Tereda, T., *Bull. Earthquake Res. Inst. Univ. Tokyo*, 1931, **10**, 393–401.
25. Skinner, B. J. and Porter, S. C., In *The Dynamic Earth, An Introduction to Physical Geology*, John Wiley, 2000, 4th edn, p. 396.
26. Beresnev, I. A. and Johnson, P. A., *Geophysics*, 1994, **59**, 1000–1017.
27. Wakita, H., Igarashi, G., Nakamura, Y., Sano, Y. and Notsu, K., *Geophys. Res. Lett.*, 1989, **16**, 417–420.
28. Abercrombie, R. E. and Mori, J., *Nature*, 1966, **381**, 303–307.

ACKNOWLEDGEMENTS. We are grateful to the Department of Science and Technology, New Delhi and the Department of Atomic Energy, Government of India, for sponsoring the present activities.

Received 11 January 2005; revised accepted 23 June 2005

## Relocation of earthquakes in the Northeast Indian region using joint hypocentre determination method

Pankaj Mala Bhattacharya<sup>1\*</sup>, Jose Pujol<sup>2</sup>, R. K. Majumdar<sup>3</sup> and J. R. Kayal<sup>1</sup>

<sup>1</sup>Central Geophysics Division, Geological Survey of India, 27, J. L. Nehru Road, Kolkata 700 016, India

<sup>2</sup>Centre for Earthquake Research and Information, The University of Memphis, Memphis, TN 38152, USA

<sup>3</sup>Department of Geological Sciences, Jadavpur University, Kolkata 700 032, India

**A set of 1941 earthquake events recorded in the northeast region of India during January 1993 – December 1999 was used for relocation by the Joint Hypocentre Determination (JHD) technique. We have utilized both P- and S-wave arrivals recorded by closely spaced 77 temporary and permanent seismic stations in the region. Results of this analysis show that (a) the average root mean square travel time residual becomes smaller than the corresponding single event locations by the HYPO71; (b) station correction varies from –2.43 to 2.32 s for P-**

**wave, and from –2.84 to 2.84 s for S-wave, indicating large crustal velocity variations in the region; (c) positive station corrections are obtained in the Shillong Plateau, Assam valley and in the Manipur fold belt, and negative station corrections are obtained in the Mikir hills, and (d) lateral variation of the velocity structure inferred from station corrections is comparable with that obtained by 3D velocity inversion using the local earthquake tomography method.**

**Keywords:** Earthquake, joint hypocentre determination, lateral velocity variation, local earthquake tomography, station correction.

THE tectonic characteristics of the northeast region of India, lat. 24–28°N and long. 89–98°E, are complicated and unique in many aspects (Figure 1). Over the last few decades, a number of investigations on seismicity and tectonics of this region have been carried out<sup>1–4</sup>. These authors mostly used HYPO71 to locate earthquakes recorded by temporary seismic stations. Kayal and Zhao<sup>5</sup> made an attempt to relocate the earthquakes by 3D inversion using temporary network data in the Shillong Plateau, southwest part of the region (Figure 1). Bhattacharya *et al.*<sup>6</sup> did fractal dimension and *b*-value studies in this region. Precise earthquake locations play an important role in understanding earthquake source processes. The earth's crust and upper mantle consist of heterogeneous structures on a regional scale. This includes complications such as discontinuities, faults, layering and random geological heterogeneities. Such complicated three-dimensional velocity structures affect the quality of locations. The effect of heterogeneous crustal velocity structure in earthquake location can be minimized by use of the Joint Hypocentre Determination (JHD) technique, which has the capability of producing significantly improved relative locations<sup>7–9</sup>. The technique owes its success to the fact that the JHD station corrections partially compensate for the lateral velocity variations, thus improving the relative location of the hypocentres.

Many authors use the Average Residual Method (ARM) for locating earthquakes<sup>10,11</sup>. The average residual is taken as station correction to minimize the travel time residual, but if the velocity model used to compute theoretical travel times is incorrect, minimization of the residual does not assure well-located events<sup>9</sup>. Therefore, using the average of the individual station residuals will not necessarily improve locations. The JHD method is designed to minimize all travel-time residuals simultaneously and to find a common set of station corrections. The events are, however, not free to move to locations that they would have when located individually. This loss of freedom results in an increase of the station residuals, which are absorbed in the station correction terms<sup>12</sup>.

In this study, an attempt has been made to use the JHD method to relocate earthquakes and to obtain *P*- and *S*-wave station corrections in the Northeast Indian region. Both *P*- and *S*-wave first-arrival observations recorded during the

\*For correspondence. (e-mail: gsicgd@cal2.vsnl.net.in)